

## Quick Reference

# MDrive® 17 Step/Direction Input with Industrial Connectors



### Notes and Warnings

Installation, configuration and maintenance must be carried out by qualified technicians only.

- Unexpected dangers may be encountered when working with this product!
- Incorrect use may destroy this product and connected components!
- The drives are not protected from reverse polarity power connection!

Detailed information on installation can be found in the user manuals. The user manuals are available for download from: <https://novantaims.com/downloads/>

### Required for Setup\*

- IBM compatible PC running Microsoft® Windows 7 or higher with available USB port.
- Monitor with a minimum of 1024 x 768 resolution.
- SPI Motor Interface (available online).
- +12 to +48 VDC linear or switching power supply.
- 0 to 5 MHz Clock signal for step clock, may be a controller high speed output or signal generator.
- SPST switch or controller I/O point to control axis direction.
- SPI communications interface (e.g., MD-CC301-001 communication converter).

If not using the MD-CC301-001 for interfacing, the following may be required:

- I/O, Power and Communications interface to 19-pin M23 circular connector (e.g., MD-CS100-000 prototype development cordset or equivalent).

\* If the MDrive is purchased with a QuickStart Kit, all the connecting cables needed for initial functional setup and system testing are included.

### Getting Started

All documentation, software, and resources are available online at: <https://novantaims.com/>

#### Connecting Power and I/O

The MDrive is configured with power and I/O combined on a single connector. Refer to "Step/Direction Input Connectivity Options" on page 2 for connecting details and available connectivity options.

#### Connecting Communications

1. Connect the USB of the SPI communications converter to the PC.
2. Connect the 19-pin M23 connector of the SPI communications converter to the MDrive.
3. Install the communication converter drivers onto PC (available online).
4. Install and open SPI Motor Interface.
5. Apply power to MDrive.
6. Parameters may be adjusted via two screens, the Motor Settings screen or the I/O Settings screen (shown below), accessible via the View menu.

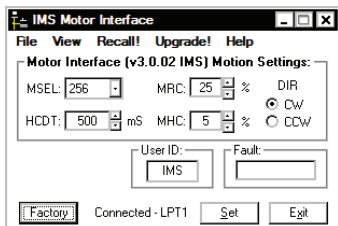

Motor Settings Screen

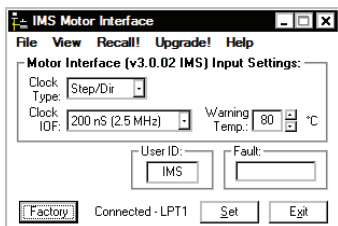

I/O Settings Screen

### General Specifications

#### Electrical Specifications

Input Voltage (+V) Range*	+12 to +48 VDC
Max Power Supply Current (Per MDrive 17)*	2 A

\*Actual Power Supply Current will depend on voltage and load.

#### Environmental Specifications

Operating Temperature (non-condensing)	Heat Sink	-40°C to +85°C
	Motor	-40°C to +100°C
Sealing		IP54

#### Isolated Input Specifications

Step Clock, Direction and Enable	
Voltage Range (Sinking or Sourcing)	+5 to +24 VDC
Current (+5V Max)	8.7 mA
Current (+24V Max)	14.6 mA

#### Motion Specifications

Digital Filter Range	50 nS to 12.9 µS (10 MHz to 38.8 kHz)
Clock Types	Step/Direction, Up/Down, Quadrature
Step Frequency (Max)	5 MHz
Step Frequency Minimum Pulse Width	100 nS
Number of Microstep Resolution Settings	20

Available Microsteps Per Revolution					
per step	1	2	4	5	8
per rev.	200	400	800	1000	1600
per step	10	16	25	32	50
per rev.	2000	3200	5000	6400	10000
per step	64	100	125	128	200
per rev.	12800	20000	25000	25600	40000
per step	250	256	180	108	127
per rev.	50000	51200	36000 <sup>1</sup>	21600 <sup>2</sup>	25400 <sup>3</sup>

1=0.01 deg/µstep 2=1 arc minute/µstep 3=0.001 mm/µstep

### Setup Parameters

#### Setup Parameters

Name	Function	Range	Units	Default
MHC	Motor Hold Current	0 to 100	Percent	5
MRC	Motor Run Current	1 to 100	Percent	25
MSEL	Microstep Resolution	See Motion Specifications	µsteps/ Full Step	256
DIR	Motor Direction Override	0/1	—	CW
HCDDT	Hold Current Delay Time	0 or 2 - 65535	mSec	500
CLK TYPE	Clock Type	See Motion Specifications	—	Step/ Direction
CLK IOF	Clock Input Filter	50 nS to 12.9 µS (10 MHz to 38.8 kHz)	nS (MHz)	200 nS (2.5MHz)
EN ACT	Enable Active High/Low	High/Low	—	High
USER ID	User ID	3 Characters Viewable ASCII	Viewable ASCII	IMS

### Mechanical Specifications

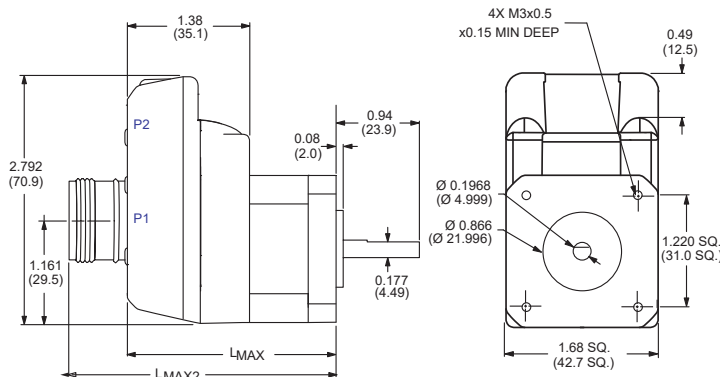

Motor Length	Dimensions in inches (mm)	
	LMAX1	LMAX2
Single	2.48 (63.00)	3.15 (80.00)
Double	2.71 (68.83)	3.38 (85.85)
Triple	3.04 (77.22)	3.71 (94.23)

# MDrive 17 IP65

## Step/Direction Input Connectivity Options

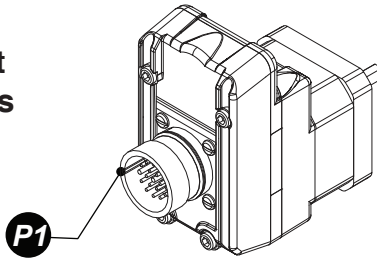

### P1 I/O, Power and Communications

M23 industrial connector (male)

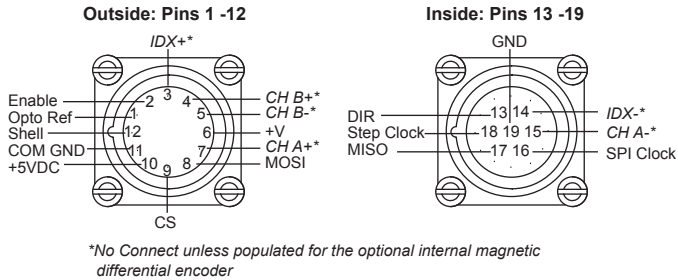

### Minimum Required Connections

The diagrams below represent the minimum connections required to operate the MDrive.

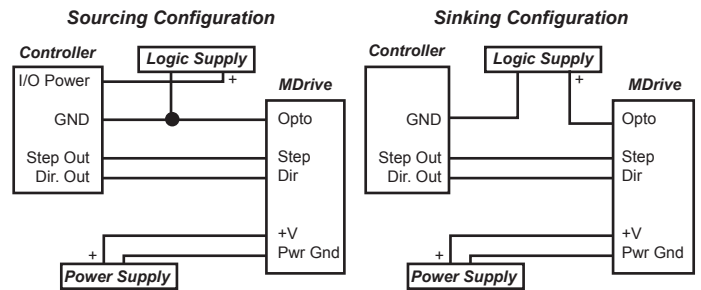

### Communications Converter p/n: MD-CC301-001

Electrically isolated in-line USB to SPI converter pre-wired with mating connector to conveniently program and set configuration parameters. A secondary cable from the mating connector provides interface to power and I/O.

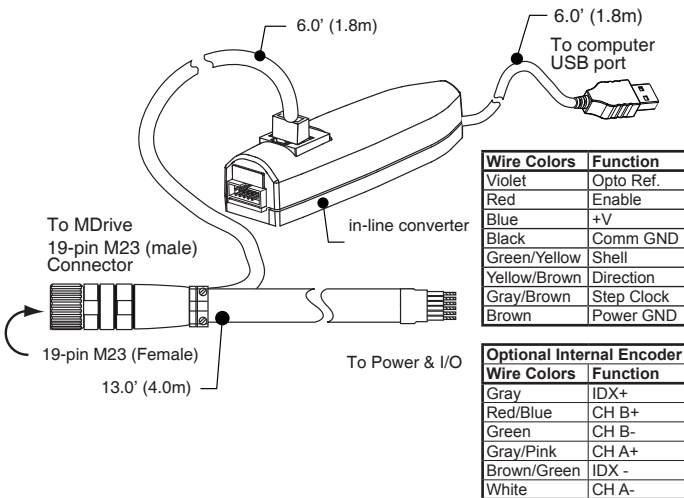

### Prototype Development Cordset p/n: MD-CS100/101-000

Speed test and development with pre-wired mating connector.

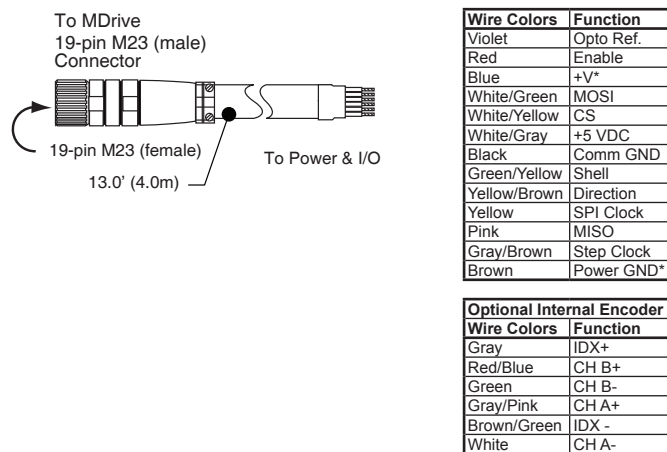

### Mating Connector Recommendations

The MD-CS100-000 is recommended with 19-pin M23 connector.

For comparable connector only, shop vendors:

- Lumberg
- Phoenix
- Turck
- RDE Connectors